

Motori da laboratorio

Laboratory motors

Moteurs pour laboratoire

tensioni e/o frequenze differenti sono fornibili a richiesta

different voltages and/or frequencies are available upon request

tensions et/ou fréquences différentes peuvent être fournies sur demande

Motore "Doriot" (fino a 22.000 giri/min), 230V ~1, 50/60 Hz

"Doriot" motor (up to 22,000 RPM), 230V ~1, 50/60 Hz

Moteurs "Doriot" (jusqu'à 22.000 tours/min), 230V ~1, 50/60 Hz

0816

Motore + reostato (0817) + trasmissione con giunto a innesto per manipolo

Motor + rheostat (0817) + transmission with slip-joint for handpiece

Moteur + rhéostat (0817) + transmission avec slip joint pour pièce à la main

Manipoli / Handpieces / Pièce à la main (pag. 6-7):

- 0806A - 0806B - 0809A/1 - 0809A/2 - 0809/1 - 0809/2 - 0811 - 0811A - 0811D - 0811D/10 - 0810/1

Ricambi / Spare parts / Pièces de rechange

Carboncini per motore / Carbon for motor / Fusains pour moteur 0816/01

Cordina 255 mm / 255 mm cord / Petite corde 255 mm 0817AA

Cordina 250 mm / 250 mm cord / Petite corde 250 mm 0817AN

Cordina 280 mm / 280 mm. cord / Petite corde 280 mm 0817AP

Cordina 317 mm / 317 mm cord / Petite corde 317 mm 0817AR

Puleggia / Pulley / Poulie 0817B

Terminale a snodo / Joint terminal / Terminal à rotule 0817C

Indotto motore / Motor armature / Induit moteur 0817D

Gruppo motore / Motor group / Groupe moteur 0817E

Trasmissione con terminale / Transmission with terminal / Transmission avec terminal 0817F

Trasmissione senza terminale / Transmission without terminal / Transmission sans terminal 0817G

Olio lubrificante / Lubricating oil / Huile lubrifiante 0817H

Reostato 5 velocità / 5 speed rheostat / Rhéostat avec 5 vitesses 0817

Reostato elettronico / Electronic rheostat / Rhéostat électronique 0817/10



Motore a sospensione "F" e albero flessibile, 230V ~1, 50/60 Hz

Hanging motor "F" and flexible shaft, 230V ~1, 50/60 Hz

Moteur suspendus "F" et arbre flexible, 230V ~1, 50/60 Hz

0800H

Motore 230 Watt + flessibile + reostato 5 velocità (8.000 ÷ 22.000 giri/min)

230 Watt motor + flexible shaft + 5 speed rheostat (8,000 ÷ 22,000 RPM)

Moteur 230 Watt + arbre flexible + rhéostat 5 vitesses (8.000 ÷ 22.000 tuors/min)

0800H/02

Motore 230 Watt + flessibile + reostato Contronic (3.000 ÷ 20.000 giri/min)

230 Watt motor + flexible shaft + rheostat Contronic (3,000 ÷ 20,000 RPM)

Moteur 230 Watt + arbre flexible + Contronic rheostat (3,000 ÷ 20,000 tuors/min)

Manipoli / Handpieces / Pièce à la main (pag. 6-7):

- 0806A - 0806B - 0809A/1 - 0809A/2 - 0809/1 - 0809/2 - 0811 - 0811A - 0811D - 0811D/10 - 0810/1

Ricambi / Spare parts / Pièces de rechange

Flessibile rinforzato "F", innesto girevole, albero ø 5 mm 0800H/09

"F" reinforced flexible shaft with revolving coupling, 5 mm ø shaft

Arbre flexible renforcé "F", embrayage pivotant, arbre ø 5 mm

Flessibile rinforzato "F", giunto a innesto, albero ø 5 mm 0800H/10

"F" reinforced flexible shaft with slip-joint, 5 mm ø shaft

Arbre flexible renforcé "F" avec slip joint, arbre ø 5 mm

Flessibile rinforzato "DG", giunto a innesto, albero ø 5 mm 0800H/20

"DG" reinforced flexible shaft with slip-joint, 5 mm ø shaft

Arbre flexible renforcé "DG", avec slip joint, arbre ø 5 mm

Albero anima "F", ø 5 mm 0800H/11

"F" core shaft, 5 mm. ø shaft

Arbre âme "F", ø 5 mm

Flessibile rinforzato "F", giunto a innesto, albero ø 6 mm 0800H/15

"F" reinforced flexible shaft with slip-joint, 6 mm ø shaft

Arbre flexible renforcé "F" avec slip joint, arbre ø 6 mm

Albero anima "F", ø 6 mm 0800H/16

"F" spare core shaft, 6 mm ø shaft

Arbre âme "F", ø 6 mm



Motori a bilico

Hanging motors

Moteurs suspendus

tensioni e/o frequenze differenti sono fornibili a richiesta

different voltages and/or frequencies are available upon request

tensions et/ou fréquences différentes peuvent être fournies sur demande



Motore "MDM" per albero flessibile, 230V ~1, 50/60 Hz

"MDM" motor for flexible shaft, 230V ~1, 50/60 Hz

Moteur "MDM" pour arbre flexible, 230V ~1, 50/60 Hz

	Potenza motore Motor power Puissance du moteur	Velocità Speed Vitesse	albero flessibile (escluso) flexible shaft (not included) arbre flexible (exclus)
0800C/04	160 Watt	4.000 x 1/min	art. 0805/2 - 0803/4
0800C/18	290 Watt	18.000 x 1/min	art. 0803/4 - 0805/3
0800C/180	290 Watt	18.000 x 1/min	art. 0800H/10 - 0800H/15

Manipoli / Handpieces / Pièce à la main (pag. 6-7):

- 0806A - 0806B - 0809A/1 - 0809A/2 - 0809/1 - 0809/2 - 0811 - 0811A - 0811D - 0811D/10 - 0810/1

Reostati / Rheostats / Rhéostats (pag. 8):

- 0813 - 0813/10



Motore "MDM" per albero flessibile, 230V ~1, 50/60 Hz

"MDM" motor for flexible shaft, 230V ~1, 50/60 Hz

Moteur "MDM" pour arbre flexible, 230V ~1, 50/60 Hz

	Potenza motore Motor power Puissance du moteur	Velocità Speed Vitesse	albero flessibile (escluso) flexible shaft (not included) arbre flexible (exclus)
0800E	140 Watt	18.000 x 1/min	art. 0803/4 - 0805/3

Manipoli / Handpieces / Pièce à la main (pag. 6-7):

- 0806A - 0806B - 0809A/1 - 0809A/2 - 0809/1 - 0809/2 - 0811 - 0811A - 0811D - 0811D/10 - 0810/1

Reostati / Rheostats / Rhéostats (pag. 8):

- 0813 - 0813/10



Motore per albero flessibile (attacco ø 8 mm) per argentieri, 230V ~1, 50/60 Hz

Motor for flexible shaft (ø 8 mm joint) for silversmiths, 230V ~1, 50/60 Hz

Moteur pour arbre flexible (joint ø 8 mm) pour argentiers, 230V ~1, 50/60 Hz

	Potenza motore Motor power Puissance du moteur	Velocità Speed Vitesse	flessibile e manipolo (escluso) flexible shaft (not included) arbre flexible (exclus)
0801B	140 Watt	15.000 x 1/min	art. 0804/1
0801A	140 Watt	18.000 x 1/min	art. 0804/1
0801D	300 Watt	22.000 x 1/min	art. 0804/1

Reostati / Rheostats / Rhéostats (pag. 8):

- 0817 - 0817/10



0804/1	Albero flessibile (attacco ø 8 mm) + manipolo fisso + 4 pinze (ø 2,3 - 3 - 4 - 6 mm) Flexible shaft (ø 8 mm joint) with fixed handpiece + 4 chucks (ø 2.3 - 3 - 4 - 6 mm) Arbre flexible (joint ø 8 mm) avec pièce à main fixe + 4 pinces (ø 2,3 - 3 - 4 - 6 mm)
---------------	---

Ricambi / Spare parts / Pièces de rechange

Anima frusta / Core shaft / Ame du flexible	0804A/1
Pinza / Chuck / Pince ø 2,3 mm	0807/82
Pinza / Chuck / Pince ø 3,0 mm	0807/83
Pinza / Chuck / Pince ø 4,0 mm	0807/84
Pinza / Chuck / Pince ø 6,0 mm	0807/86

Flessibili e manipoli rotativi a innesto

Flexible shaft and rotary handpieces

Arbre flexibles et pièce à main



	Albero flessibile, giunto a innesto per manipolo a forare o martellare Flexible shaft with slip-joint for boring or hammering handpiece Arbre flexible avec slip joint pour pièce à main, pour percer ou marteler
0805/2	Per velocità / For speeds / Par vitesse = 3.600 ÷ 10.000 RPM
0805/3	Per velocità / For speeds / Par vitesse = 15.000 ÷ 18.000 RPM
Ricambi / Spare parts / Pièces de rechange	
Anima frusta / Core for shaft / Ame du flexible x 0805/2	0805A
Anima frusta / Core for shaft / Ame du flexible x 0805/3	0805A/10
Clips / clips / clips x 0805/2 - 0805/3	0805B
Terminali + clips / Terminal + clips / Terminaux + clips x 0850/3 - 0805/3	0805C



0803/4	Albero flessibile con manipolo fisso a forare + 4 pinze (ø 0 - 1 - 2,3 - 3 mm) Flexible shaft with fixe drilling handpiece + 4 chucks (ø 0 - 1 - 2,3 - 3 mm) Arbre flexible avec pièce à main fixe pour percer + 4 pinces (ø 0 - 1 - 2,3 - 3 mm)
---------------	---



0806B	Manipolo a forare, giunto a innesto + 4 pinze (ø 0 - 1 - 2,3 - 3 mm) Drilling handpiece, slip-joint + 4 chucks (ø 0 - 1 - 2,3 - 3 mm) Pièce à main de perçage avec slip joint + 4 pinces (ø 0 - 1 - 2,3 - 3 mm)
--------------	--

Ricambi / Spare parts / Pièces de rechange	
Anima frusta / Core for shaft / Âme du flexible	0803A
Bottoncino bloccapinza / Clamp block button / Bouton blocage de la pince	0808A
Nasello di serraggio / Threaded ring nut / Collier de serrage	0808
Pinza / Chuck / Pince = ø 0,00 mm	0807/1
Pinza / Chuck / Pince = ø 1,00 mm	0807/2
Pinza / Chuck / Pince = ø 1,50 mm	0807/3
Pinza / Chuck / Pince = ø 2,00 mm	0807/4
Pinza / Chuck / Pince = ø 2,35 mm	0807/5
Pinza / Chuck / Pince = ø 3,00 mm	0807/6



0806A	Manipolo a forare "SW", giunto a innesto + pinza (ø 2,35 mm) "SW" drilling handpiece, slip-joint + chuck (ø 2,35 mm) Pièce à main de perçage "SW", avec slip joint + pince (ø 2,35 mm)
--------------	---

Ricambi / Spare parts / Pièces de rechange	
Serie di 9 pinze / Set of 9 chucks / Serie de pinces	0806A/10
(ø 0,55 - 0,80 - 1,05 - 1,55 - 2,05 - 2,40 - 2,55 - 3,10 - 3,20 mm)	
Pinza singola / Single chuck / Pince seul	0806A/20
(ø 0,55 - 0,80 - 1,05 - 1,55 - 2,05 - 2,40 - 2,55 - 3,10 - 3,20 mm)	



0809A/21	Manipolo a forare "SILVER", giunto a innesto, pinza fissa ø 2,35 mm "SILVER" drilling handpiece, slip-joint, fixed collect ø 2,35 mm Pièce à main de perçage "SILVER", avec slip joint, pince fixe ø 2,35 mm
-----------------	---

Ricambi / Spare parts / Pièces de rechange	
Pinza / Chuck / Pince = ø 1,00 mm	0809A/51
Pinza / Chuck / Pince = ø 2,35 mm	0809A/52
Pinza / Chuck / Pince = ø 3,00 mm	0809A/53



0809A/1	Manipolo a forare "DG", giunto a innesto, pinza fissa ø 2,35 mm "DG" drilling handpiece, slip-joint, fixed chuck ø 2,35 mm Pièce à main de perçage "DG", avec slip joint, pince fixe ø 2,35 mm
0809A/2	Manipolo a forare "DG", giunto a innesto, pinza fissa ø 3,0 mm "DG" drilling handpiece, slip-joint, fixed chuck ø 3,00 mm Pièce à main de perçage "DG", avec slip joint, pince fixe ø 3,0 mm

Ricambi / Spare parts / Pièces de rechange	
Pinza / Chuck / Pince = ø 2,35 mm	0809A/3
Pinza / Chuck / Pince = ø 3,00 mm	0809A/4

Manipoli rotativi a innesto

Rotary handpieces

Pièce à main



0809/1 Manipolo a forare tipo "F", giunto a innesto, pinza ø 2,35 mm

Type "F" drilling handpiece, with slip-joint, chuck ø 2.35 mm

Pièce à main de perçage type "F" avec slip joint, pince ø 2,35 mm

0809/2 Manipolo a forare tipo "F", giunto a innesto, pinza ø 3,00 mm

Type "F" drilling handpiece, slip-joint, chuck ø 3.00 mm

Pièce à main de perçage type "F" avec slip joint, pince ø 3,00 mm

Ricambi / Spare parts / Pièces de rechange

Pinza / Chuck / Pince = ø 2,35 mm 0809/3

Pinza / Chuck / Pince = ø 3,00 mm 0809/4



0810/1 Manipolo a forare con mandrino (ø 0 ÷ 4 mm) + chiave, giunto a innesto

Drilling handpiece with self-centering chuck (ø 0 ÷ 4 mm) + key, with slip-joint

Pièce à main de perçage avec mandrin (ø 0 ÷ 4 mm) + clé, avec slip joint

Ricambi / Spare parts / Pièces de rechange

Mandrino autocentrante / Self-centering chuck / Mandrin à centrage automatique 0810/2

Chiavetta mandrino / Chuck key / Clé pour mandrin 0810A



0810B/10 Manipolo a martellare tipo "F", giunto a innesto, con una punta N° 1

Type "F" hammer handpiece, slip-joint, with 1 no. 1 bit

Pièce à main pour marteler type "F" avec slip joint, avec 1 pointe N°1

Ricambi / Spare parts / Pièces de rechange

Punta N° 1 / No. 1 bit / Pointe N° 1 0810B/15

Punta N° 3 / No. 3 bit / Pointe N° 3 0810B/18

Punta N° 8 / No. 8 bit / Pointe N° 8 0810B/28

Punta N° 11 / No.11 bit / Pointe N°11 0810B/31



0811 Manipolo a martellare, giunto a innesto, con 2 punte

Hammer handpiece, slip-joint, with 2 bits

Pièce à main pour marteler avec slip joint, avec 2 pointes

Ricambi / Spare parts / Pièces de rechange

Punta temperata / Hardened bit / Pointe trempée 0812A



0811A Manipolo a martellare "SW", giunto a innesto, con 1 punta tonda

"SW" hammer handpiece, slip-joint, with 1 round bit

Pièce à main pour marteler "SW" avec slip joint, avec 1 pointe ronde

Ricambi / Spare parts / Pièces de rechange

Porta punta / Bit holder / Porte pointe 0812/11

Punta non temperata / Non-hardened bit / Pointe non trempée 0812

Punta temperata / Hardened bit / Pointe trempée 0812/10

Serie di 9 punte temperate / Set of 9 hardened bits / Serie de 9 pointes trempées 0812/09

3 x ● (ø 0,50 - 1,00 - 2,10); 2 x ■ (1,0 - 1,6 mm)

1 x ● (1,20 x 2,10 mm); 3 x ■ (0,50 x 1,0 - 0,80 x 1,50 - 1,20 x 2,50 mm)



0811D Manipolo a martellare "Dimaika", giunto a innesto + 1 punta

"Dimaika" hammer handpiece, slip-joint, with 1 bit

Pièce à main pour marteler "Dimaika" avec slip joint, avec 1 pointe

0811D battuta normale / normal stroke / butée normale

0811D/10 battuta soft / soft stroke / butée soft

Ricambi / Spare parts / Pièces de rechange

Punta non temperata / No-hardened bit / Pointe non trempée 0812B

Punta diamantata / Diamond bit / Pointe de diamantée 0812B/20

Accessori per motori a bilico

Accessories for hanging motors
Accessoires pour moteurs suspendus



- 0817** **Reostato a pedale, regolazione 5 velocità (8.000 ÷ 22.000 giri/min)**
Foot rheostat, 5-speed (8,000 ÷ 22,000 RPM)
Rhéostat à pédale, réglage 5 vitesses (8.000 ÷ 22.000 tours/min)
- 0817/10** **Reostato a pedale, regolazione elettronica (3.000 ÷ 20.000 giri/min)**
Pedal rheostat, electronic adjustment (3,000 ÷ 20,000 RPM)
Rhéostat à pédale, réglage électronique (3.000 ÷ 20.000 tours/min)



- 0813** **Reostato a pedale con regolazione elettronica, 150 Watt - 230V ~1**
Foot rheostat with electronic adjustment, 150 Watt - 230V ~1
Rhéostat à pédale à réglage électronique, 150 Watt - 230V ~1
- 0813/10** **Reostato a pedale con regolazione elettronica, 150 Watt - 230V ~1 - CE**
Foot rheostat with electronic adjustment, 150 Watt - 230V ~1 - CE
Rhéostat à pédale à réglage électronique 150 Watt - 230V ~1 - CE
- 0813A** **Reostato a pedale con regolazione elettronica, 80 Watt - 110V**
Foot rheostat with electronic adjustment, 80 Watt - 110V
Rhéostat à pédale à réglage électronique 80 Watt - 110V

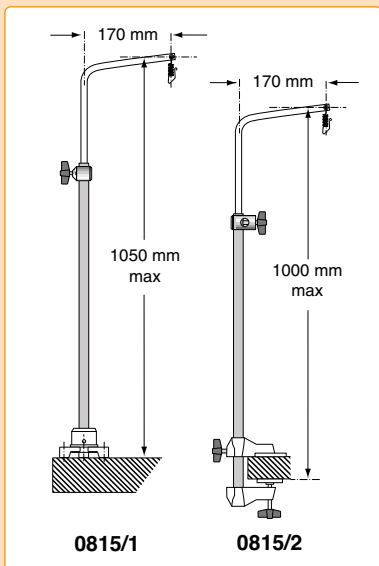

- 0815/1** **Con base orizzontale per fissaggio su banco con viti**
With horizontal base for fixing to bench with screws
Avec base horizontale pour visser sur banc
- 0815/2** **Con morsetto per fissaggio al banco**
With clamp for fixing to bench
Avec serre-joint pour fixation sur banc
- 0815A** **Molla per colonnina**
Column spring
Ressort pour colonne

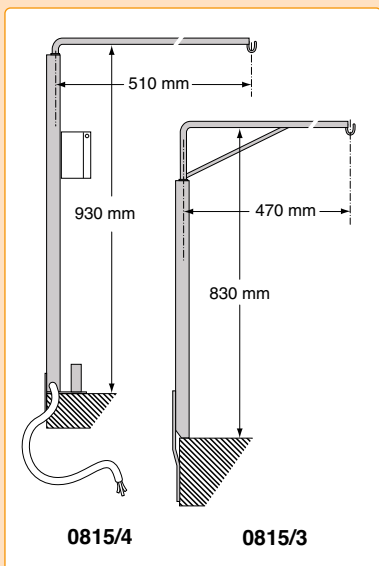

- 0815/3** **Colonnine di supporto, altezza fissa, braccio girevole**
Stands column, fixed height, rotating arm
Colonnes de support, hauteur fixe, bras pivotant
- 0815/4** **Con staffa verticale per fissaggio su sponda banco**
With vertical bracket for fixing to bench
Avec châssis vertical pour fixation sur côté bâti
- 0815/4** **Con staffa verticale per fissaggio su sponda banco + presa elettrica**
With vertical bracket for fixing to side of bench + electrical socket
Avec châssis vertical pour fixation sur côté bâti + prise électrique
- 0815A** **Molla per colonnina**
Column spring
Ressort pour colonne