

Trafile tonde

Round drawing dies
Filières rondes

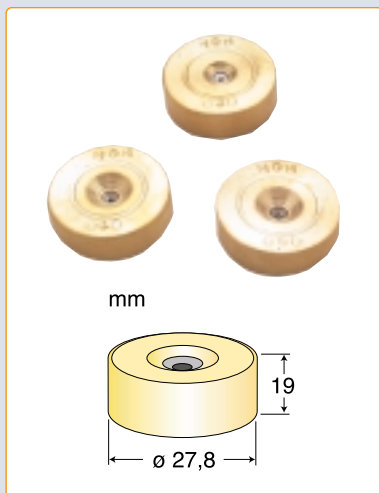

Trafile diamante, sezione tonda, supporto ottone (misure speciali fornibili a richiesta)

Diamond drawing dies, round shape, brass support (special sizes available on request)

Filière en Diamant, section ronde, support en laiton (mesures spéciales sur demande)

0545/10	∅ 0,10 mm	0545/23	∅ 0,75 mm	0545/36	∅ 1,40 mm
0545/11	∅ 0,15 mm	0545/24	∅ 0,80 mm	0545/37	∅ 1,45 mm
0545/12	∅ 0,20 mm	0545/25	∅ 0,85 mm	0545/38	∅ 1,50 mm
0545/13	∅ 0,25 mm	0545/26	∅ 0,90 mm	0545/39	∅ 1,55 mm
0545/14	∅ 0,30 mm	0545/27	∅ 0,95 mm	0545/40	∅ 1,60 mm
0545/15	∅ 0,35 mm	0545/28	∅ 1,00 mm	0545/41	∅ 1,65 mm
0545/16	∅ 0,40 mm	0545/29	∅ 1,05 mm	0545/42	∅ 1,70 mm
0545/17	∅ 0,45 mm	0545/30	∅ 1,10 mm	0545/43	∅ 1,75 mm
0545/18	∅ 0,50 mm	0545/31	∅ 1,15 mm	0545/44	∅ 1,80 mm
0545/19	∅ 0,55 mm	0545/32	∅ 1,20 mm	0545/45	∅ 1,85 mm
0545/20	∅ 0,60 mm	0545/33	∅ 1,25 mm	0545/46	∅ 1,90 mm
0545/21	∅ 0,65 mm	0545/34	∅ 1,30 mm	0545/47	∅ 1,95 mm
0545/22	∅ 0,70 mm	0545/35	∅ 1,35 mm	0545/48	∅ 2,00 mm

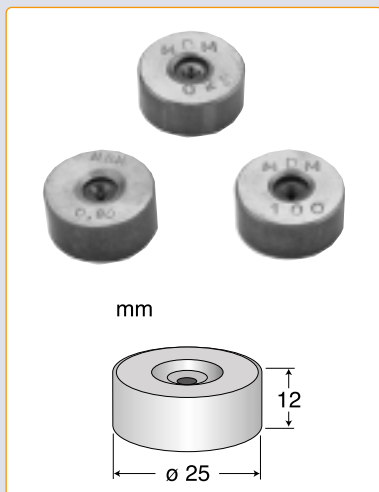

Trafile in Widia®, sezione tonda, supporto ottone cromato (misure speciali fornibili a richiesta)

Widia® drawing dies, round shape, chrome coated brass support (special sizes available on request)

Filière en Widia®, section ronde, support en laiton (mesures spéciales sur demande)

0546/10	∅ 0,15 mm	0546/27	∅ 1,00 mm	0546/48	∅ 2,05 mm
0546/01	∅ 0,16 mm	0546/28	∅ 1,05 mm	0546/49	∅ 2,10 mm
0546/02	∅ 0,17 mm	0546/29	∅ 1,10 mm	0546/50	∅ 2,15 mm
0546/03	∅ 0,18 mm	0546/30	∅ 1,15 mm	0546/51	∅ 2,20 mm
0546/04	∅ 0,19 mm	0546/31	∅ 1,20 mm	0546/52	∅ 2,25 mm
0546/11	∅ 0,20 mm	0546/32	∅ 1,25 mm	0546/53	∅ 2,30 mm
0546/12	∅ 0,25 mm	0546/33	∅ 1,30 mm	0546/54	∅ 2,35 mm
0546/13	∅ 0,30 mm	0546/34	∅ 1,35 mm	0546/55	∅ 2,40 mm
0546/14	∅ 0,35 mm	0546/35	∅ 1,40 mm	0546/56	∅ 2,45 mm
0546/15	∅ 0,40 mm	0546/36	∅ 1,45 mm	0546/57	∅ 2,50 mm
0546/16	∅ 0,45 mm	0546/37	∅ 1,50 mm	0546A/10	∅ 2,55 mm
0546/17	∅ 0,50 mm	0546/38	∅ 1,55 mm	0546A/11	∅ 2,60 mm
0546/18	∅ 0,55 mm	0546/39	∅ 1,60 mm	0546A/12	∅ 2,65 mm
0546/19	∅ 0,60 mm	0546/40	∅ 1,65 mm	0546A/13	∅ 2,70 mm
0546/20	∅ 0,65 mm	0546/41	∅ 1,70 mm	0546A/14	∅ 2,75 mm
0546/21	∅ 0,70 mm	0546/42	∅ 1,75 mm	0546A/15	∅ 2,80 mm
0546/22	∅ 0,75 mm	0546/43	∅ 1,80 mm	0546A/16	∅ 2,85 mm
0546/23	∅ 0,80 mm	0546/44	∅ 1,85 mm	0546A/17	∅ 2,90 mm
0546/24	∅ 0,85 mm	0546/45	∅ 1,90 mm	0546A/18	∅ 2,95 mm
0546/25	∅ 0,90 mm	0546/46	∅ 1,95 mm	0546A/19	∅ 3,00 mm
0546/26	∅ 0,95 mm	0546/47	∅ 2,00 mm		



Trafile tonda su piastra con inserti intercambiabili in Widia

Round drawplates with interchangeable inserts in Widia

Filière ronde sur plaque avec noyaux interchangeables en Widia

	misure / mesures / mesures	fori / holes / trous
0558/5	∅ 4,00 ÷ 2,55 mm	30
0558/10	∅ 2,25 ÷ 3,25 mm	21
0558/9	∅ 2,25 ÷ 1,25 mm	21
0558/7	∅ 1,25 ÷ 0,25 mm	21
0558/7	Inserti di ricambio / Spare inserts / Noyaux de rechange	

Trafile tonde

Round drawing dies
Filières rondes

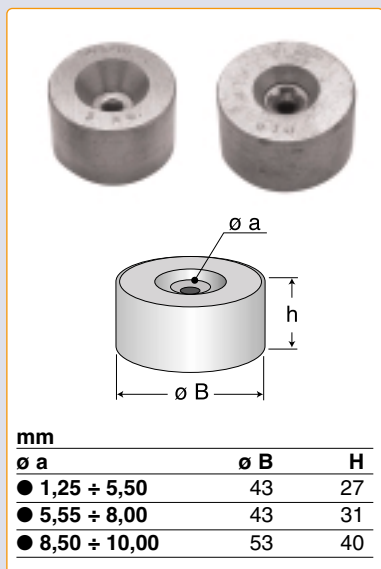

Trafile in Widia®, sezione tonda, supporto acciaio (misure speciali fornibili a richiesta)

Widia® drawing dies, round shape, steel support (special sizes available on request)

Filière en Widia®, section ronde, support en acier (mesures spéciales sur demande)

0546B/10	ø 1,25 mm	0546B/35	ø 3,80 mm	0546B/60	ø 5,55 mm
0546B/11	ø 1,40 mm	0546B/36	ø 3,90 mm	0546B/61	ø 5,65 mm
0546B/12	ø 1,60 mm	0546B/37	ø 4,00 mm	0546B/62	ø 5,70 mm
0546B/13	ø 1,80 mm	0546B/38	ø 4,10 mm	0546B/63	ø 5,80 mm
0546B/14	ø 1,90 mm	0546B/39	ø 4,20 mm	0546B/64	ø 5,85 mm
0546B/15	ø 2,00 mm	0546B/40	ø 4,30 mm	0546B/65	ø 5,90 mm
0546B/16	ø 2,10 mm	0546B/41	ø 4,35 mm	0546B/66	ø 6,00 mm
0546B/17	ø 2,30 mm	0546B/42	ø 4,40 mm	0546B/67	ø 6,10 mm
0546B/18	ø 2,35 mm	0546B/43	ø 4,45 mm	0546B/68	ø 6,20 mm
0546B/19	ø 2,40 mm	0546B/44	ø 4,50 mm	0546B/69	ø 6,30 mm
0546B/20	ø 2,60 mm	0546B/45	ø 4,55 mm	0546B/70	ø 6,40 mm
0546B/21	ø 2,70 mm	0546B/46	ø 4,60 mm	0546B/71	ø 6,50 mm
0546B/22	ø 2,75 mm	0546B/47	ø 4,70 mm	0546B/72	ø 7,00 mm
0546B/23	ø 2,80 mm	0546B/48	ø 4,75 mm	0546B/73	ø 7,20 mm
0546B/24	ø 2,90 mm	0546B/49	ø 4,80 mm	0546B/74	ø 7,30 mm
0546B/25	ø 3,00 mm	0546B/50	ø 4,85 mm	0546B/75	ø 7,40 mm
0546B/26	ø 3,10 mm	0546B/51	ø 4,90 mm	0546B/76	ø 7,50 mm
0546B/27	ø 3,20 mm	0546B/52	ø 5,00 mm	0546B/81	ø 8,00 mm
0546B/28	ø 3,25 mm	0546B/53	ø 5,10 mm	0546B/77	ø 8,50 mm
0546B/29	ø 3,30 mm	0546B/54	ø 5,15 mm	0546B/82	ø 8,70 mm
0546B/30	ø 3,35 mm	0546B/55	ø 5,20 mm	0546B/78	ø 9,00 mm
0546B/31	ø 3,40 mm	0546B/56	ø 5,30 mm	0546B/79	ø 9,50 mm
0546B/32	ø 3,50 mm	0546B/57	ø 5,40 mm	0546B/80	ø 10,00 mm
0546B/33	ø 3,60 mm	0546B/58	ø 5,45 mm		
0546B/34	ø 3,70 mm	0546B/59	ø 5,50 mm		

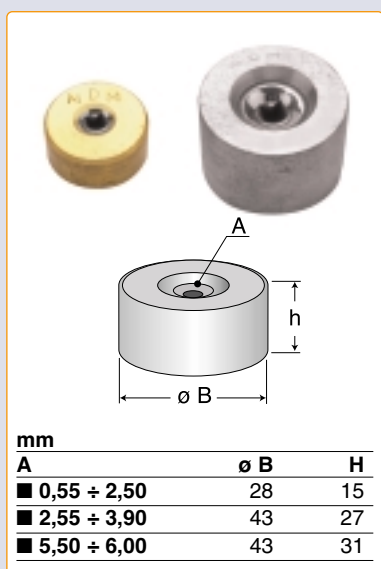

Trafile in Widia®, sezione quadra, supporto ottone o acciaio (misure speciali fornibili a richiesta)

Widia® drawing dies, square shape, brass or steel support (special sizes available on request)

Filière en Widia®, section carrée, support en laiton ou en acier (mesures spéciales sur demande)

0546E/15	0,55 x 0,55 mm	0546E/36	1,60 x 1,60 mm	0546E/57	2,65 x 2,65 mm
0546E/16	0,60 x 0,60 mm	0546E/37	1,65 x 1,65 mm	0546E/58	2,70 x 2,70 mm
0546E/17	0,65 x 0,65 mm	0546E/38	1,70 x 1,70 mm	0546E/59	2,75 x 2,75 mm
0546E/18	0,70 x 0,70 mm	0546E/39	1,75 x 1,75 mm	0546E/60	2,80 x 2,80 mm
0546E/19	0,75 x 0,75 mm	0546E/40	1,80 x 1,80 mm	0546E/61	2,85 x 2,85 mm
0546E/20	0,80 x 0,80 mm	0546E/41	1,85 x 1,85 mm	0546E/62	2,90 x 2,90 mm
0546E/21	0,85 x 0,85 mm	0546E/42	1,90 x 1,90 mm	0546E/63	2,95 x 2,95 mm
0546E/22	0,90 x 0,90 mm	0546E/43	1,95 x 1,95 mm	0546E/64	3,00 x 3,00 mm
0546E/23	0,95 x 0,95 mm	0546E/44	2,00 x 2,00 mm	0546E/65	3,10 x 3,10 mm
0546E/24	1,00 x 1,00 mm	0546E/45	2,05 x 2,05 mm	0546E/66	3,20 x 3,20 mm
0546E/25	1,05 x 1,05 mm	0546E/46	2,10 x 2,10 mm	0546E/67	3,30 x 3,30 mm
0546E/26	1,10 x 1,10 mm	0546E/47	2,15 x 2,15 mm	0546E/68	3,40 x 3,40 mm
0546E/27	1,15 x 1,15 mm	0546E/48	2,20 x 2,20 mm	0546E/69	3,50 x 3,50 mm
0546E/28	1,20 x 1,20 mm	0546E/49	2,25 x 2,25 mm	0546E/70	3,60 x 3,60 mm
0546E/29	1,25 x 1,25 mm	0546E/50	2,30 x 2,30 mm	0546E/71	3,70 x 3,70 mm
0546E/30	1,30 x 1,30 mm	0546E/51	2,35 x 2,35 mm	0546E/72	3,80 x 3,80 mm
0546E/31	1,35 x 1,35 mm	0546E/52	2,40 x 2,40 mm	0546E/73	3,90 x 3,90 mm
0546E/32	1,40 x 1,40 mm	0546E/53	2,45 x 2,45 mm	0546E/81	5,50 x 5,50 mm
0546E/33	1,45 x 1,45 mm	0546E/54	2,50 x 2,50 mm	0546E/82	6,00 x 6,00 mm
0546E/34	1,50 x 1,50 mm	0546E/55	2,55 x 2,55 mm		
0546E/35	1,55 x 1,55 mm	0546E/56	2,60 x 2,60 mm		

Piastre trafila acciaio

Steel drawplates

Filières a etirer

Trafila a fori multipli su piastra di acciaio. Le forme e misure di seguito illustrate sono disponibili a magazzino. Su richiesta vengono inoltre fornite le forme illustrate a pagine 6 e 7. Per quest'ultime vi preghiamo di citare sempre il numero di identificazione riportato sopra ciascuna figura e di precisare le misure minime e massime della trafila.

Multiple holes drawplates, on steel plate. Sizes and measures showing are available from stock. Shapes showing on pages 6 and 7 are available on request.

For these latter please always specify either identification number showing over each shape and minimum and maximum hole size of the draw plate.

Filières en acier à trous multiples sur plaque. Les formes et les mesures illustrées en bas sont disponibles. Sur demande nous pouvons fournir les formes illustrées à pages 6 et 7. Pour ces dernières veuillez toujours mentionner le numéro d'identification écrit sur chaque forme et préciser mesures minimales et maximales de la filière.

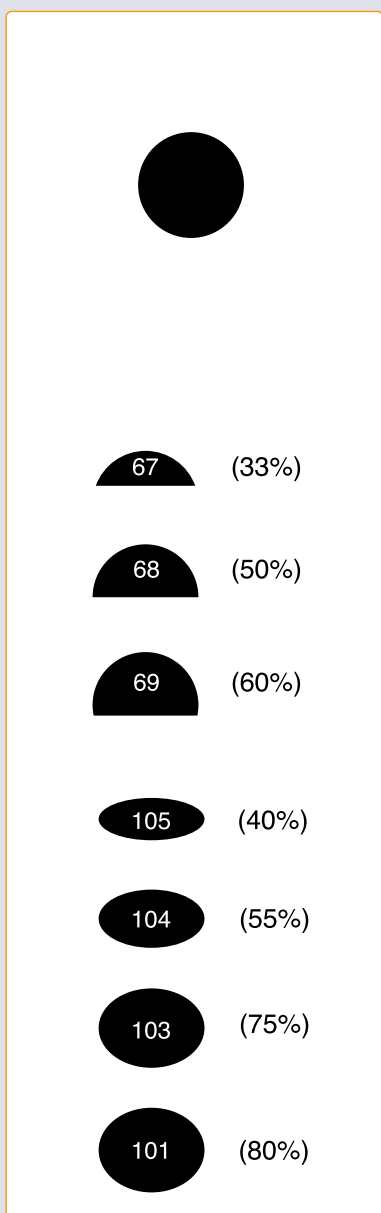

	misure / measures / mesures	fori / holes / trous	sagoma / shape / profil
0550/24	∅ 15 ÷ 12 mm	31	
0550/23	∅ 14 ÷ 12 mm	20	
0550/22	∅ 12 ÷ 10 mm	31	
0550/21	∅ 12 ÷ 9 mm	31	
0550/19	∅ 10 ÷ 8 mm	20	
0550/17	∅ 9 ÷ 6 mm	31	
0550/16	∅ 8 ÷ 5 mm	31	
0550/15	∅ 6 ÷ 3 mm	31	
0550/14	∅ 5 ÷ 3 mm	20	
0550/13	∅ 5 ÷ 2 mm	31	
0550/120	∅ 3 ÷ 1 mm	31	
0550/12	∅ 3 ÷ 0,5 mm	31	
0550/11	∅ 2 mm ÷ F	31	
0550/10	∅ 1 mm ÷ F	20	
0551B/5	12 x 3,96 ÷ 9 x 1,80 mm	31	67
0551B/6	9 x 2,97 ÷ 6 x 1,98 mm	31	67
0551B/4	6 x 1,98 ÷ 3 x 0,99 mm	31	67
0551B/2	3 x 0,99 ÷ 1 x 0,33 mm	20	67
0552A/5	12 x 6,00 ÷ 9 x 4,50 mm	31	68
0552A/6	9 x 4,50 ÷ 6 x 3,00 mm	31	68
0552A/4	6 x 3,00 ÷ 3 x 1,50 mm	31	68
0552A/2	3 x 1,50 ÷ 1 x 0,50 mm	20	68
0552/5	12 x 7,20 ÷ 9 x 5,40 mm	31	69
0552/6	9 x 5,40 ÷ 6 x 3,60 mm	31	69
0552/4	6 x 3,60 ÷ 3 x 1,80 mm	31	69
0552/2	3 x 1,80 ÷ 1 x 0,60 mm	20	69
0551A/55	12 x 4,80 ÷ 9 x 3,60 mm	31	105
0551A/54	9 x 3,60 ÷ 6 x 2,40 mm	31	105
0551A/53	6 x 2,40 ÷ 3 x 1,20 mm	31	105
0551A/52	3 x 1,20 ÷ 1 x 0,40 mm	20	105
0551A/6	12 x 6,60 ÷ 9 x 4,95 mm	31	104
0551A/5	9 x 4,95 ÷ 6 x 3,30 mm	31	104
0551A/4	6 x 3,30 ÷ 3 x 1,65 mm	31	104
0551A/2	3 x 1,65 ÷ 1 x 0,55 mm	20	104
0551/6	12 x 9,00 ÷ 9 x 6,75 mm	31	103
0551/5	9 x 6,75 ÷ 6 x 4,50 mm	31	103
0551/4	6 x 3,30 ÷ 3 x 1,65 mm	31	103
0551/2	3 x 1,65 ÷ 1 x 0,55 mm	20	103
0551/04	12 x 9,60 ÷ 9 x 7,20 mm	31	101
0551/03	9 x 7,20 ÷ 6 x 4,80 mm	31	101
0551/02	6 x 4,80 ÷ 3 x 2,40 mm	31	101
0551/010	3 x 2,40 ÷ 1 x 0,80 mm	20	101

Piastre trafila acciaio

Steel drawplates

Filières a etirer

Trafille a fori multipli su piastra di acciaio. Le forme e misure di seguito illustrate sono disponibili a magazzino. Su richiesta vengono inoltre fornite le forme illustrate a pagine 6 e 7. Per quest'ultime vi preghiamo di citare sempre il numero di identificazione riportato sopra ciascuna figura e di precisare le misure minime e massime della trafila.

Multiple holes drawplates, on steel plate. Sizes and measures showing are available from stock. Shapes showing on pages 6 and 7 are available on request.

For these latter please always specify either identification number showing over each shape and minimum and maximum hole size of the draw plate.

Filières en acier à trous multiples sur plaque. Les formes et les mesures illustrées en bas sont disponibles. Sur demande nous pouvons fournir les formes illustrées à pages 6 et 7. Pour ces dernières veuillez toujours mentionner le numéro d'identification écrit sur chaque forme et préciser mesures mimimes et maximales de la filière.



314 (38%)

10

175 (50%)

139 (87%)

305 (140%)

468
12 righe
12 slots
12 rainures

467
14 righe
14 slots
14 rainures

462
18 righe
18 slots
18 rainures

463
20 righe
20 slots
20 rainures

466
24 righe
24 slots
24 rainures

	misure / measures / mesures	fori / holes / trous	sagoma / shape / profil
0551B/07	12 x 4,56 ÷ 9 x 3,42 mm	31	314
0551B/06	9 x 3,42 ÷ 6 x 2,28 mm	31	314
0551B/04	6 x 2,28 ÷ 3 x 1,14 mm	31	314
0551B/02	3 x 1,14 ÷ 1 x 0,38 mm	20	314
0554/21	14 ÷ 12 mm	20	10
0554/20	10 ÷ 8 mm	20	10
0554/19	9 ÷ 6 mm	31	10
0554/18	8 ÷ 5 mm	31	10
0554/17	6 ÷ 3 mm	31	10
0554/16	5 ÷ 3 mm	20	10
0554/15	5 ÷ 2 mm	31	10
0554/13	3 ÷ 1 mm	20	10
0554/12	3 ÷ 0,5 mm	31	10
0554/11	2 mm ÷ F	31	10
0554/10	1 mm ÷ F	20	10
0555/6	12 x 6,00 ÷ 9 x 4,50 mm	31	175
0555/5	9 x 4,50 ÷ 6 x 3,00 mm	31	175
0555/4	6 x 3,00 ÷ 3 x 1,50 mm	31	175
0555/2	3 x 1,50 ÷ 1 x 0,50 mm	20	175
0553/6	12 x 10,44 ÷ 9 x 7,83 mm	31	139
0553/5	9 x 7,83 ÷ 6 x 5,22 mm	31	139
0553/4	6 x 5,22 ÷ 3 x 2,61 mm	31	139
0553/2	3 x 2,61 ÷ 1 x 0,87 mm	20	139
0553/1	3 x 2,61 ÷ 0,5 x 0,43 mm	31	139
0556/8	8,57 x 12 ÷ 6,42 x 9 mm	31	305
0556/7	6,42 x 9 ÷ 4,28 x 6 mm	31	305
0556/5	4,28 x 6 ÷ 2,14 x 3 mm	31	305
0556/2	2,14 x 3 ÷ 0,71 x 1 mm	20	305
0556F/13	12 ÷ 9 mm	31	468
0556F/12	9 ÷ 6 mm	31	468
0556F/11	6 ÷ 3 mm	31	468
0556F/10	3 ÷ 1 mm	20	468
0556I/13	12 ÷ 9 mm	31	467
0556I/12	9 ÷ 6 mm	31	467
0556I/11	6 ÷ 3 mm	31	467
0556I/10	3 ÷ 1 mm	20	467
0556G/13	12 ÷ 9 mm	31	462
0556G/12	9 ÷ 6 mm	31	462
0556G/11	6 ÷ 3 mm	31	462
0556G/10	3 ÷ 1 mm	20	462
0556L/13	12 ÷ 9 mm	31	463
0556L/12	9 ÷ 6 mm	31	463
0556L/11	6 ÷ 3 mm	31	463
0556L/10	3 ÷ 1 mm	20	463
0556N/13	12 ÷ 9 mm	31	466
0556N/12	9 ÷ 6 mm	31	466
0556N/11	6 ÷ 3 mm	31	466
0556N/10	3 ÷ 1 mm	20	466

Piastre trafilata acciaio
Steel drawplates
Filières a etirer

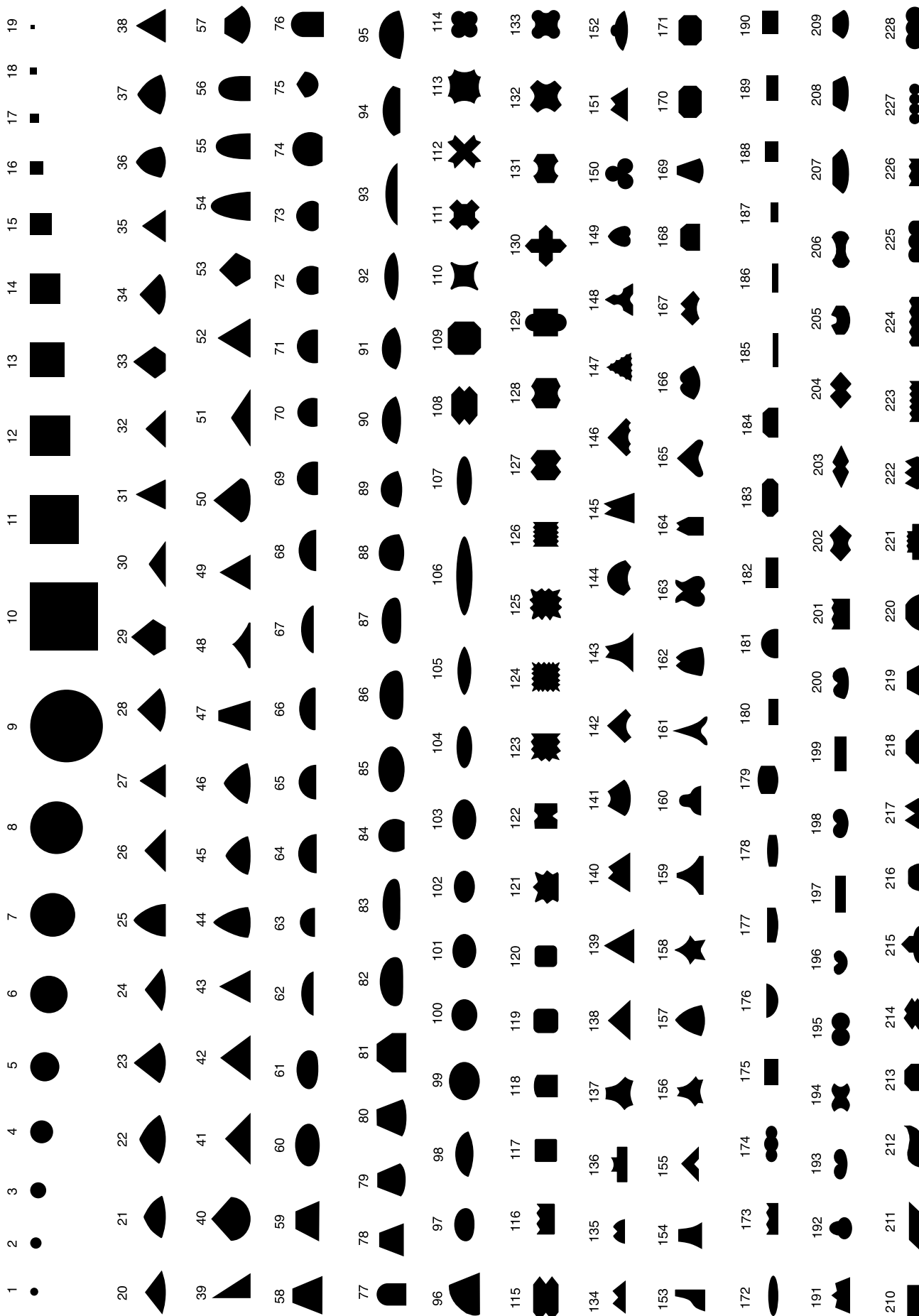

Piastre trafila acciaio
Steel drawplates
Filières a etirer

